

# Dyna-King, Inc. PROFESSIONAL

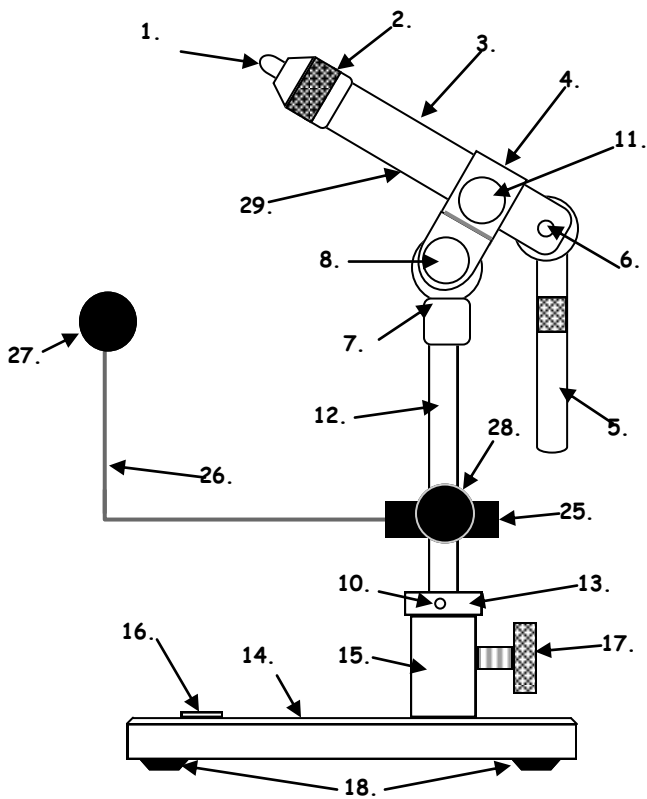

Bobbin Hanger available separately for purchase. Set collar available on clamp models only

Clamp Base

Opposite side of ADAPTOR #4

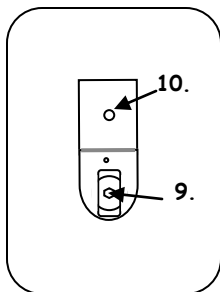
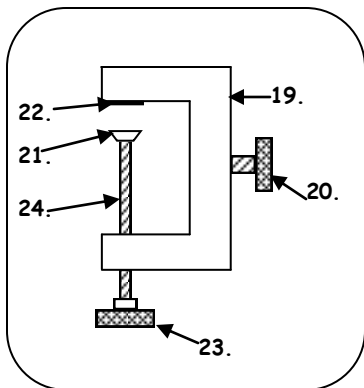

## PROFESSIONAL PARTS LIST

1. Jaws	16. Name Plate
2. Forcing Cone	17. Base Lock Screw
3. Body	18. Base Feet
4. Adaptor	19. Large Clamp Base
5. Cam Handle	20. Clamp Lock Screw
6. Cam Pin	21. Clamp Shoe
7. Pivot Head	22. Felt Pad
8. Pivot Lock Nut	23. Clamp Handle
9. Pivot Lock Screw	24. Clamp Screw
10. Set Screw (2)	25. Bobbin Mount
11. Tension Screw	26. Bobbin Hanger Wire
12. Shaft	27. Bobbin Rest
13. Set Collar	28. Bobbin Hanger Screw
14. Large Pedestal Base	29. Serial number
15. Column	

Some tiers choose to move the vise to the horizontal position for the purpose of rotation tying. To change the angle of the vise, first remove the vise from it's base & then loosen the PIVOT NUT. Grasp the BODY in one hand & the shaft in the other and pull the two parts away from each other until you feel the lock pin disengage. You may now move the vise to any of the 4 positions you'd like. When you select your position press the two components together until you hear them snap into place & tighten the PIVOT NUT. Now you're ready to use your vise.

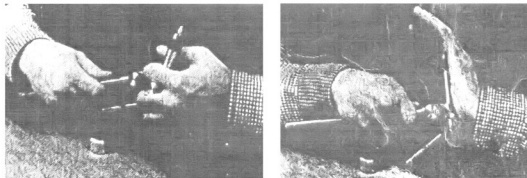
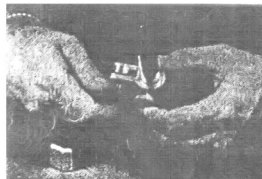

## PROFESSIONAL

**JAWS:** To open the JAWS simply raise the CAM HANDLE to the upward position. Insert the hook you will use for tying into the JAW, using the appropriate size groove. Each of these grooves will accommodate a different range of hook sizes. Large hooks will be held best in the rear grooves. Medium size hooks should be held in the groove closest to the JAW tips. Any hook too small to be held securely in the grooves will be held best by the serrated section of the JAW tips.

**FORCING CONE:** To adjust tension on the hook, raise your CAM HANDLE and screw the FORCING CONE counterclockwise to reduce tension & clockwise to increase tension. It is important to never over tighten the FORCING CONE. Over tightening the FORCING CONE, or adjusting the FORCING CONE while the JAWS are closed & the CAM HANDLE is in the down position, may cause the JAWS to lock & possibly remain closed.

**TO CLEAN & MAINTAIN:** You may wipe down your vise with a soft cloth & a light machine oil, or a lubricant spray. It is important to periodically grease the inside of the FORCING CONE and the outside shank of the JAWS with a marine boat grease, taking care not to get grease between the JAWS.

Pedestal vises come with a 7" shaft.  
Clamp vises come with a 9" shaft.

DYNA-KING, INC.  
597 SANTANA DRIVE, UNIT A  
CLOVERDALE, CA 95425, USA  
Toll Free (800) 396-2546  
Ph(707) 894-5566 • Fax (707) 894-5566  
www.dyna-king.com  
Email: info@dyna-king.com