

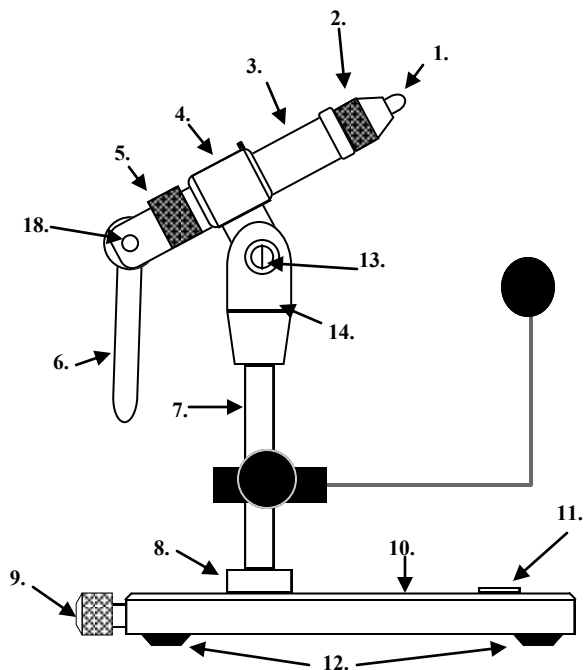

DYNA-KING, INC.

VOYAGER II



Bobbin Hanger sold separately. Set collar available on clamp models only

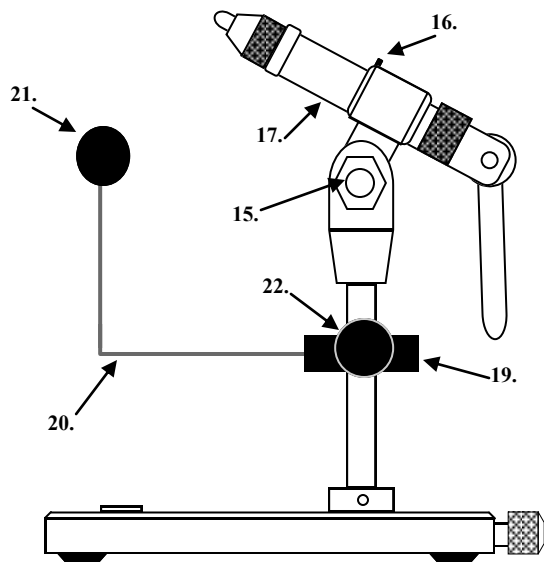

PARTS LIST

- | | |
|-------------------|------------------------|
| 1. Jaws | 12. Pedestal Base Feet |
| 2. Forcing Cone | 13. Pivot Screw |
| 3. Vise Body | 14. Adaptor |
| 4. Adaptor Sleeve | 15. Hex Nut |
| 5. Stop Collar | 16. Brass Pin |
| 6. Cam Handle | 17. Serial Number |
| 7. Shaft | 18. Cam Pin |
| 8. Set Collar | 19. Bobbin Mount |
| 9. Base Screw | 20. Bobbin Wire |
| 10. Pedestal Base | 21. Bobbin Rest |
| 11. Name Plate | 22. Bobbin Screw |

FEATURES

- Infinite angle position
- Heavier base
- 360° rotation
- Travel pouch included
- Bobbin Hanger Included

INFORMATION

To **clean and maintain** the vise it may be wiped down with a soft cloth with light machine oil, or a lubricant spray. It is important to periodically grease the inside of the forcing cone and the outside of the jaws with a marine boat grease, taking care not to get grease between the jaws.

To **adjust the jaw to the size hook being tied**, first open the vise jaw by raising the cam handle. Next, unscrew and adjust the forcing cone until the cam can be brought to the closed position, which is straight down, leaving enough space between the jaw for the desired hook size. It is important to not over tighten the forcing cone.

To **change the tying angle** on the vise, firmly grasp the vise body with one hand and tilt the vise body to the desired angle. Resistance to the angle change is pre-set at the factory. However, the amount of resistance to the angle change may be increased or decreased by loosening or tightening the hexagon acorn nut using the 7/16" box wrench included with your vise.

To **rotate the vise 360°**, grasp the black Stop collar, located at the rear of the vise body and push toward the jaws, disengaging the brass lock pin from the notch in the adaptor. See diagram below.

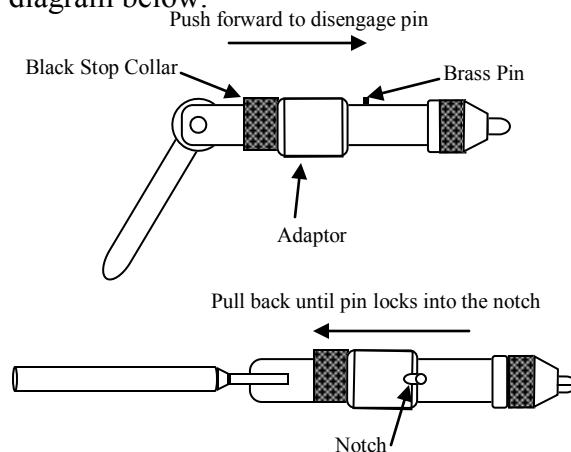

NEVER OVERTIGHTEN OR ADJUST THE FORCING CONE!
OVERTIGHTENING THE FORCING CONE OR ADJUSTING THE CONE WHILE THE CAM IS IN THE DOWN POSITION & THE JAWS ARE CLOSED MAY CAUSE THE JAWS & CONE TO LOCK & POSSIBLY REMAIN CLOSED

DYNA-KING®
 597 SANTANA DRIVE, UNIT A
 CLOVERDALE, CA 95425 USA
 Toll Free (800) DYNA-KIN • Ph (707) 894-5566
 FAX (707) 894-5990
 www.dyna-king.com • EMAIL: info@dyna-king.com