



**DYNA-KING®**  
*World's Finest Hand Crafted Fly-Tying Vises and Accessories*

## **EXTENDED BODY & PARACHUTE TOOL**

The Dyna-King **Extended Body & Parachute Tool**, referred to as **EB&P Tool**, was designed specifically for tying extended body & parachute flies.

The **EB&P Tool** is adjustable to nearly any position around your vise. To assemble the **EB&P Tool (Figure-1)**, first insert your vise shaft into the 3/8" diameter hole of the **Beam (A)**. Now place your vise, with the **Beam** attached, back into your vise clamp. Insert the longer end of the **Bent 1/4" Shaft (B)**, into the other end of the **Beam** & tighten the **Lock Screw (C)**. Next, place the **Straight 1/4" Rod (H)** into the 1/4" hole in the **Shaft Head (D)** and tighten the screw. The **Hackle Hook & Spring (E)** should be positioned on the **Straight 1/4" Rod (H)**, between the **Shaft Head (D)** and the **Terminal Head (F)**. Upon completion of assembly, the tool should appear as in the diagram below.

To tie an Extended Body fly, tie in the end of a piece of appropriately sized monofilament to a hook secured in the vise. Thread the other end of the monofilament through the small hole in the lower end of the **Terminal Head (F)**. Pull the mono taut and tighten the **Clamp Screw (G)** just enough to secure the mono. Proper positioning of the **EB&P Tool** will place the mono in a plane parallel to the vise body and extending behind the vise (**See diagrams below**). Adjusting the shaft vertically will provide greater or less clearance in the tying area. You may proceed to tie your Extended Body Fly. Using the monofilament as a core upon which to build the fly's abdomen. Upon completion, simply cut the mono at the end of the Extended Body.

To tie a **Parachute Fly (Figure-2)**, position the **Straight 1/4" Rod (H)** over the hook. Align the **Hackle Hook & Spring (E)** over the hook. With the fly ready for the parachute, hang the loop of the thread over the hanger and secure the hook with suitable tension. The parachute is now formed by tying the hackle & winding around the base of the thread loop. When fly is completed, cement and trim thread loop.

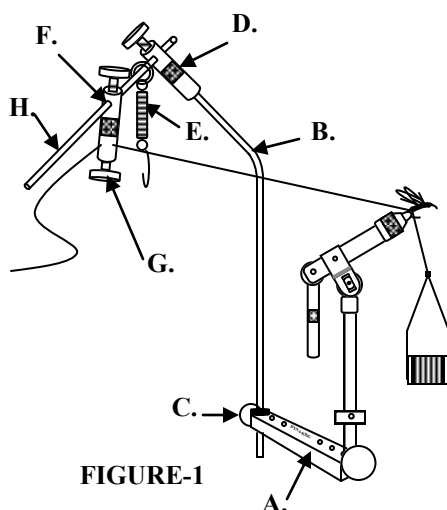

FIGURE-1

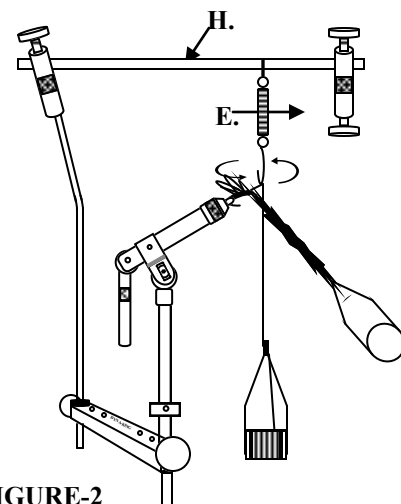

FIGURE-2