

— DYNA-KING® —
World's Finest Hand Crafted Fly-Tying Vises and Accessories

TUBE-FLY 2002

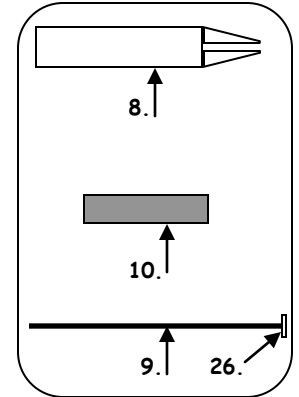
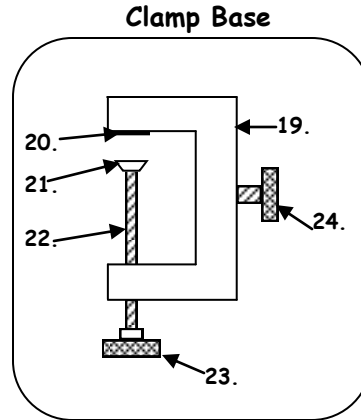
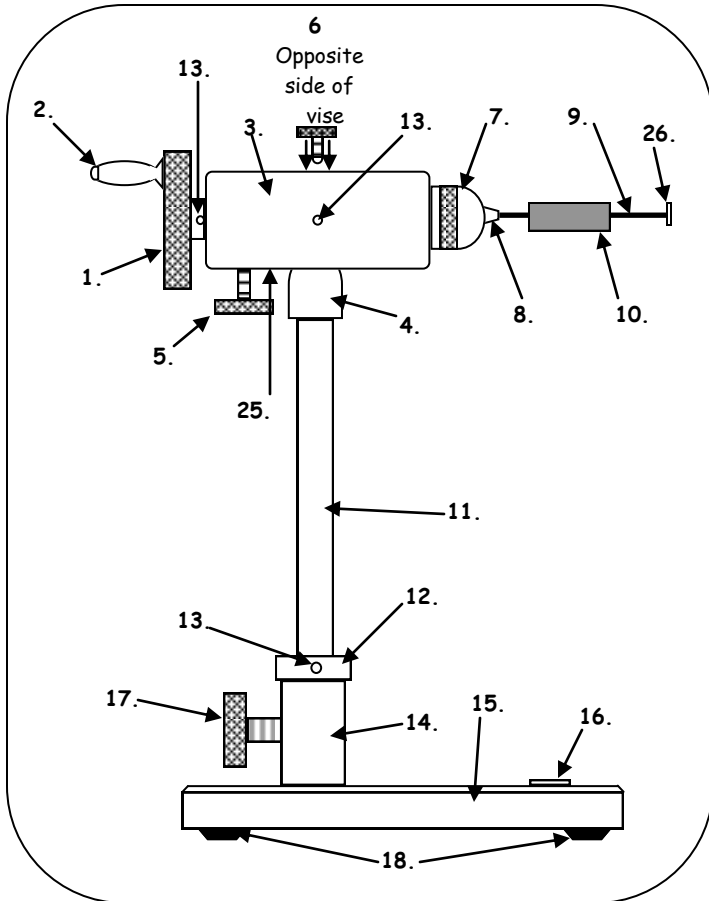

PARTS LIST:

- | | |
|--|-------------------------|
| 1. Actuator | 15. Large Pedestal Base |
| 2. Actuator Handle | 16. Name Plate |
| 3. Bearing housing | 17. Base Lock Screw |
| 4. Shaft Adaptor | 18. Base Feet |
| 5. Lock Screw | 19. Large Clamp base |
| 6. Tension Screw | 20. Felt Pad |
| 7. Collet Nut | 21. Clamp Shoe |
| 8. Collet (2) | 22. Clamp Screw |
| 9. Mandrel (2) | 23. Clamp Handle |
| 10. Tube (2) | 24. Clamp Lock Screw |
| 11. Shaft | 25. Serial Number |
| 12. Set collar-available
on clamp models only | 26. Mandrel Head (2) |
| 13. Set Screw (3) | |
| 14. Column | |

TO BEGIN TYING

First, select a MANDREL (#9) to fit the TUBE (#10) you will use. Slide the TUBE onto the MANDREL against the MANDREL head.

Remove the collet nut by unscrewing. Insert the appropriate COLLET (#8) into the vise as shown and replace the collet nut. Do not tighten.

Insert the end of the MANDREL protruding from TUBE piece into COLLET. While holding the TUBE piece firmly against the end of the vise, tighten the COLLET NUT (#7) lightly. Test the hold by pulling on the MANDREL head. Tighten only enough to secure the MANDREL and prevent the TUBE from rotating.

Tying Tip: If you are experiencing trouble with a TUBE rotating on the MANDREL, just dab a small amount of 5 minute epoxy just under the MANDREL head. Allow the glue to set up and dry thoroughly. This will give enough grip for the TUBE to stay stationary.